

Backstopping Clutches

LCB

Backstopping Ball Bearing Supported, Sprag Clutches



- Wide speed range between 0 and (LCB-200 3600/ LCB-400 1800 RPM).
- Wide temperature operating range between -13 and 194 °F (-25 and 90 °C).
- Wide bore range for fan shaft (LCB-200 Max 3.5”/ LCB-400 Max 5”) (89mm and 127mm).
- Torque capacity (LCB-200 150 lb.ft (200Nm)/ LCB-400 850 lb.ft (1150Nm).
- Drag torque, negligible, less than 1.5 lb.in.
- Easy to install requiring only LCB-200 1.125” and LCB-400 2” of shaft engagement.
- Lubricated for life (no maintenance required).
- Bearing life L10 is over 200 years.
- Compact design with only LCB-200 2-7/8”/ LCB-400 4.95” required space beyond the shaft end of the fan.
- Self actuated with no power or utility required to operate.
- Shaft mounted design has been tested to over 200% torque capacity.
- Flexible torque arm design.
- Meets ISO “G” 30 Balance

For further information see Installation and Maintenance Bulletin No. A-3041, P-4051.

The Model LCB-200 and 400 were designed to economically meet the problem of windmilling in fan applications.

The Model LCB-200 and 400 are economical low torque clutches which can accommodate a range of shaft diameters between 1-7/8” and 5”.

These clutches can be installed on vertical or horizontal fan shafts without the use of a key. These clutches are maintenance free and easy to install.

The Model LCB-201 was designed to mount onto “QD” & “TL” style bushing/connections.

For LCB-400 Flange Adapter Accessory to be used for easy mounting onto “QD” & “TL” style bushing/connections.

Typical Mounting Arrangements

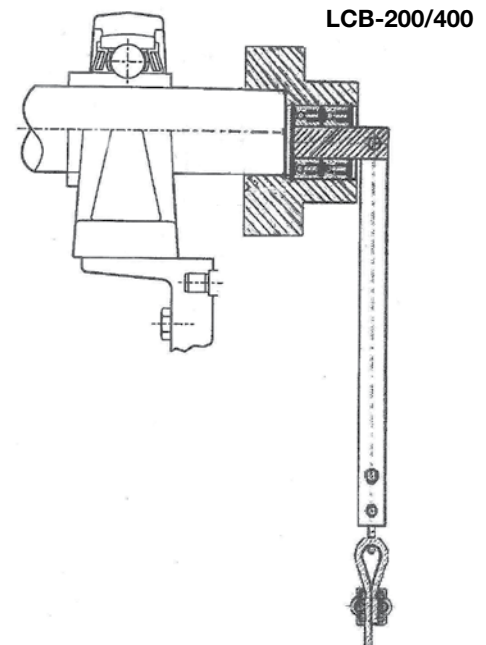

Specifications

Formsprag Model LCB				
Size	Torque Capacity lb.ft. (Nm)	Max Speed (RPM)	Resistance After Run-in lb.in. (Ncm)	Shipping Weight (lbs)
200	150 (200)	3,600	1.07 (12)	10.0
201	150 (200)	3,600	1.07 (12)	13.2
400	850 (1150)	1,800	1.78 (20)	70.0

LCB-200/400

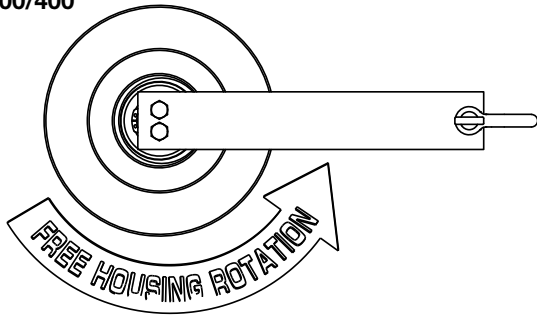

Counterclockwise rotation as shown is left hand.
Right hand rotation is opposite.

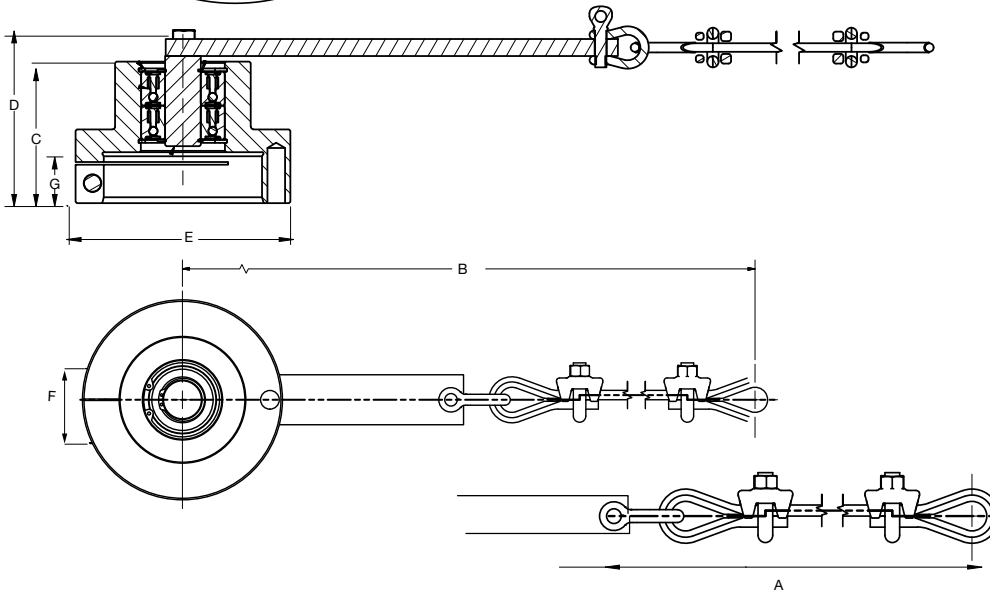

LCB-201

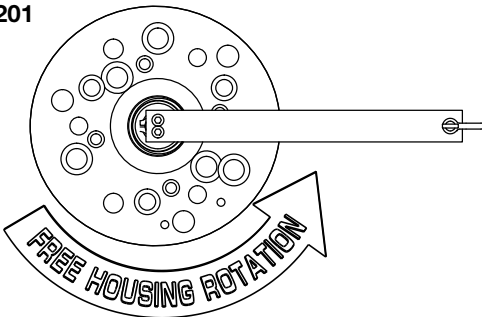

Counterclockwise rotation as shown is left hand.
Right hand rotation is opposite.

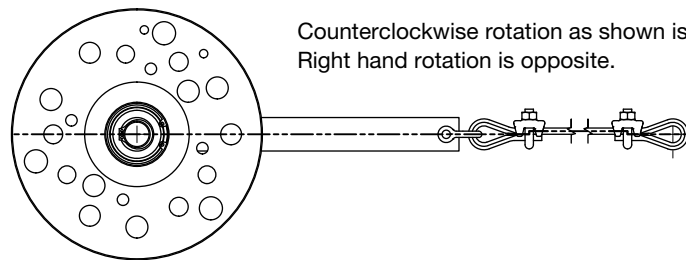

The Hole Patterns Will Work With But Not Limited To The Following Bushings:

3X 4030 Taper-Lock 5/8-11 X 1-3/4

3X 3525 Taper-Lock 1/2-13 X 1-1/2

3X E QD Bushings 1/2-13 X 2-3/4

3X F QD Bushings 9/16-12 X 3-5/8

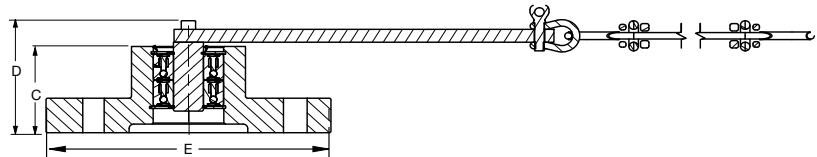

Dimensions inches (mm)

Model	A	B	C	D	E	F		G
						Min. Bore Size	Max. Bore Size	
LCB-200	Approx. 16 (406.40)	9.25 (234.95)	3.13 (79.50)	3.98 (101.09)	4.75 (120.65)	Ø1.85 (46.99)	Ø3.50 (88.90)	1.12 (28.45)
LCB-201	Approx. 16 (406.40)	9.25 (234.95)	2.50 (63.50)	3.25 (82.55)	7.50 (190.5)	Flanged Housing with TL and QD bushings connections.		0.25 (6.35)
LCB-400	Approx. 32 (812.80)	10.75 (273.05)	5.38 (136.65)	6.95 (176.53)	8.00 (203.20)	Ø3.15 (80.01)	Ø5.00 (127.00)	2.00 (50.80)